

Quartz Crystal Primer

Introduction

For crystal oscillator design and engineering success, the design engineer must first understand the crystal resonator.

The crystal, as the highest Q component in the oscillator circuit, will have the most impact on the circuit. Therefore, correctly specifying the crystal is critical to a well-designed oscillator. This mini primer will cover some of the most misunderstood parameters of a quartz crystal.

Figure 1 shows the electrical equivalent circuit of the crystal resonator.

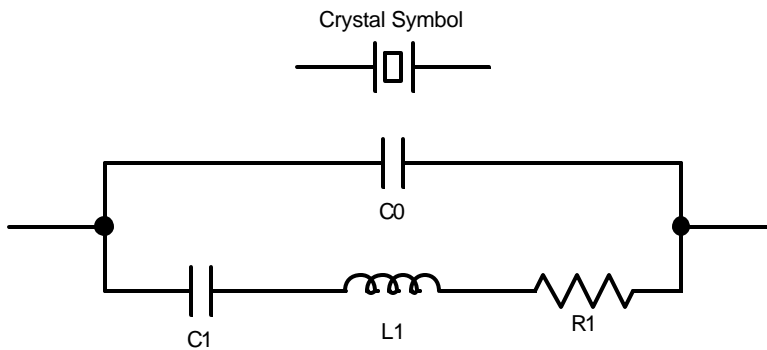

Figure 1: Crystal Symbol and its Single Mode, 1-Port, Crystal Resonator Equivalent Circuit

In Figure 1, C_1 , L_1 and R_1 form the motional arm of the crystal resonator. C_0 is the Shunt capacitance, which is primarily formed from the electrodes of the crystal plus the strays of the holder. The shunt capacitance C_0 is the only physical value in the equivalent circuit. This parameter can actually be measured with a simple capacitance meter. The motional arm components (C_1 , L_1 and R_1), on the other hand, are equivalents and, therefore, are not real. Note that this equivalent is for the fundamental response only, and additional motional arms can be added for each of the overtones and spurious.

The Impedance equation for the crystal equivalent circuit of Figure 1 is,

$$Z(j\omega) = \frac{(1/j\omega C_0)(R_1 + 1/j\omega C_1 + j\omega L_1)}{1/j\omega C_0 + R_1 + 1/j\omega C_1 + j\omega L_1} \quad (1.1)$$

Where

$j = \text{Imaginary operator} = \sqrt{-1}$
 $\omega = \text{radian frequency} = 2\pi f$

Equation (1.1) is complex impedance but our interest will be in the imaginary part of it, or its reactance. Figure 2 depicts this.

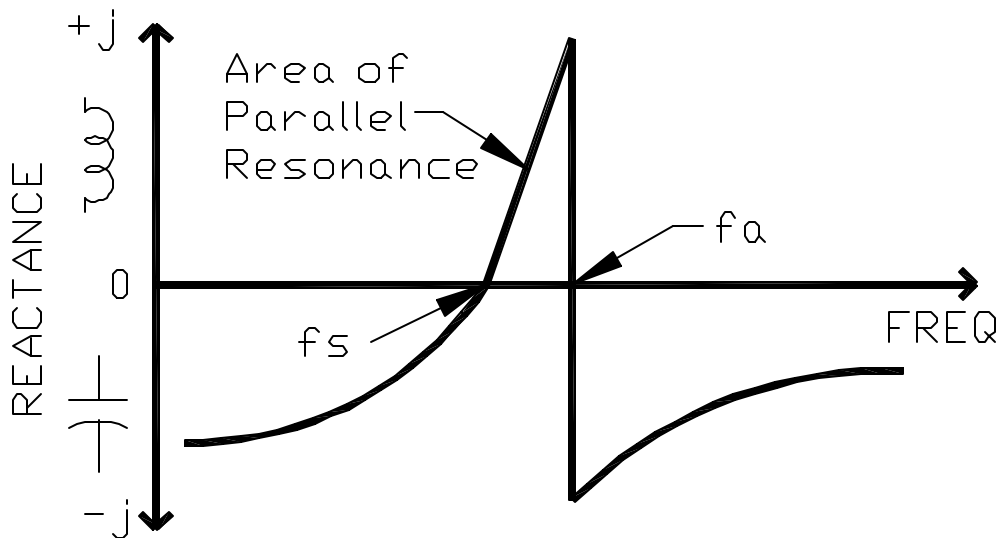

Figure 2: Plot of reactance versus frequency of a quartz crystal

There are four key facts in Figure 2.

First, f_s is the frequency at which the motional capacitance C_1 cancels the motional inductance L_1 . Second, f_s is called the “series resonance” of the crystal and is expressed by

$$f_s = \frac{1}{2\pi\sqrt{L_1 C_1}} \quad (1.2)$$

Third, the anti-resonant point or parallel resonance f_a , is where the motional inductance L_1 resonates with the parallel combination of C_1 and C_0 . Fourth, f_a is expressed by

$$f_a = \frac{1}{2\pi\sqrt{L_1 \frac{C_0 C_1}{C_0 + C_1}}} \quad (1.3)$$

Pulling the Frequency by Changing the Load Capacitance

Many applications require changing the frequency of the crystal. One example is a VCXO (Voltage Controlled Crystal Oscillator), where it is necessary to tune the operating frequency to a desired value or to vary the frequency over a desired voltage range. As the capacitive load in series with the crystal is varied, the crystal frequency is pulled. This change of the frequency with load capacitance C_L is expressed by:

$$\frac{f_L - f_s}{f_s} = \frac{\Delta f}{f_s} = \frac{C_1}{2(C_L + C_0)} \times 10^6 \text{ (in ppm)} \quad (1.4)$$

Where

f_L = frequency with the load capacitance

f_s = frequency at series resonance

C_1 = motional capacitance of crystal

C_0 = shunt capacitance of crystal

and

$$\frac{\Delta f}{f_s} = \text{fractional frequency change} \quad (1.5)$$

Note that the equation (1.4) is written as a delta from series resonance frequency to load resonance frequency. In other words, the fractional frequency changes from f_s to f_L .

Reducing the value of the load capacitance will increase the frequency of the crystal. Eventually, the frequency of f_a will be reached, but should be avoided in crystal oscillators. This leads to

$$\lim_{C_L \rightarrow 0} \left(\frac{C_1}{2(C_L + C_0)} \right) = \frac{C_1}{2C_0} \quad (1.6)$$

The result of (1.6) is the fractional frequency distance to the pole, or f_a to f_s . This is known as the zero to pole spacing, and sets the limit on the total pullability of a crystal.

A graphic representation of (1.4) of a typical pulling curve:

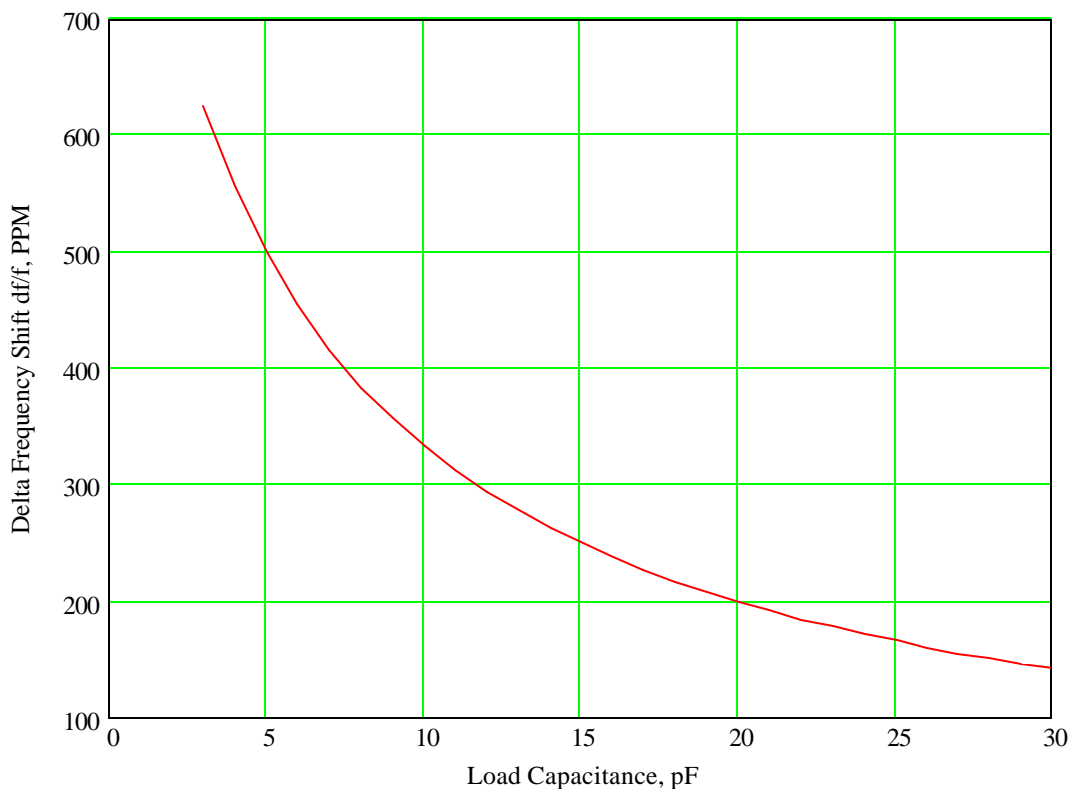

Figure 3: Plot of equation (1.4). Typical Crystal Frequency Pulling Curve vs Load Capacitance where the motional capacitance $C_1 = 0.01$ pF and the shunt capacitance $C_0 = 5$ pF. With 20 pF in series with this crystal, the frequency is +200 PPM above the Series Resonance frequency.

The first derivative of the equation (1.4) with respect to C_L results in

$$TS = -\left(\frac{C_1}{2(C_0 + C_L)^2}\right) \times 10^{-6} \text{ (in ppm/pF)} \quad (1.7)$$

Crystal manufacturers call equation (1.7) of the crystal's given load capacitance, "Trim Sensitivity". Figure 4 is the graphic representation of "Trim Sensitivity".

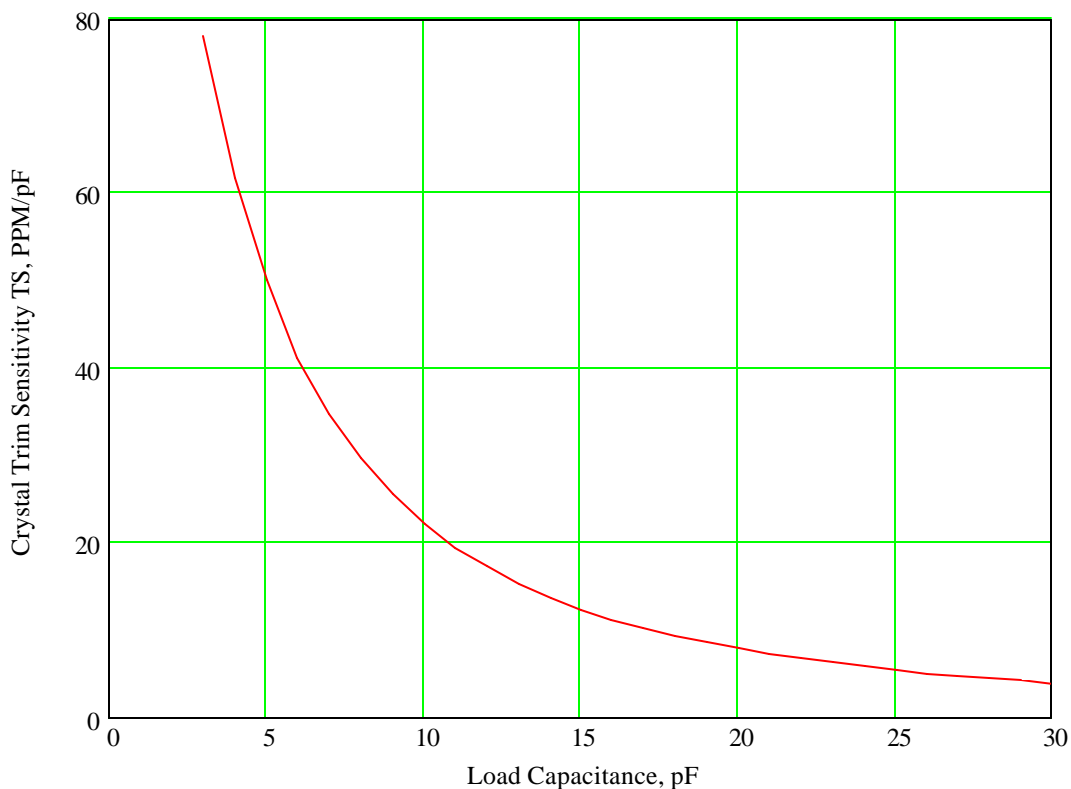

Figure 4: Plot of equation(1.7). Typical Crystal Trim Sensitivity versus Load Capacitance, where the motional capacitance $C1 = 0.01$ pF and the shunt capacitance $C0 = 5$ pF. At a C_L of 10pF, $TS = -22.22$ PPM/pF. At a $C_L = 20$ pF, $TS = -8$ PPM/pF.

The Trim Sensitivity equation (1.7) gives an important insight into how to choose the load capacitance value for the crystal. If the designer's goal is make a fixed frequency oscillator, such as in a microprocessor application, then he/she chooses a large load capacitance value like 18 - 22pF. If the designer wants to pull the crystal, then he/she chooses a small load capacitance value like 9pF - 14pF.

Crystals Have Many Responses!

All crystals have many resonant responses (See Figure 5). The first major response is called the “Fundamental”. To the right of it, is the next major response which is the 3rd Overtone, then the 5th Overtone, and so on. There are only odd overtones. The overtone responses are *not* harmonics of the fundamental. By definition, a harmonic is an exact multiple of a lower frequency. For example, the 3rd Overtone usually lies between 2.8 to 3.2 times the fundamental. So crystals have no harmonics, but overtones.

Examine Figure 5 and notice that crystal behaves like a resistor at some frequency points, and like an inductor or capacitor at other frequency regions.

The circuit topology connected to the crystal determines where to operate the crystal. In other words, the circuit forces the crystal into either fundamental, parallel, overtone or series mode. See definitions below.

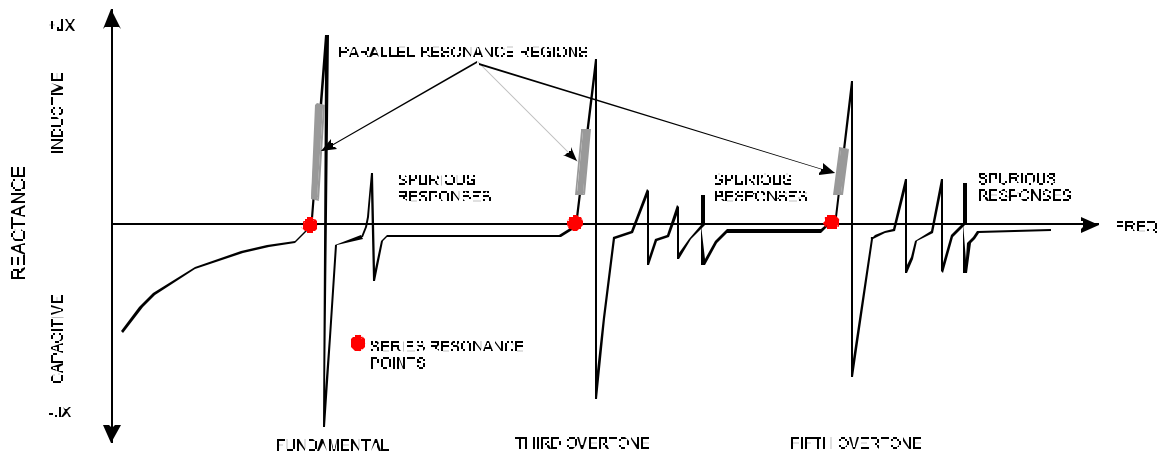

FIGURE 5

“**Load Capacitance**”: The frequency of the crystal will vary depending on the capacitive reactance in series with the crystal. Therefore, the designer must specify the capacitance value needed to calibrate the crystal to frequency. Typical values are between 9 - 32 pF; with 18 - 20 pF being the most common. The Load Capacitance is effectively placed in series with the crystal, never across it.

“Parallel Crystal”: A crystal calibrated to the desired frequency at one of the inductive regions of the crystal’s reactance curve. Since it is a region, the designer must identify exactly where in the region he/she needs the crystal to operate. The exact point in the region is controlled by the value of the load capacitance.

“Series Crystal”: A crystal calibrated to the desired frequency at one of the resistive points on the crystal’s reactance curve . The resistive point can be on the fundamental or one of the overtone responses. No Load Capacitance needs to be specified, since it is a point of operation and not a region.

“Fundamental Crystal”: A crystal designed and calibrated to the desired frequency on the lowest major resonant response. A Fundamental crystal can be calibrated as “Series” or “Parallel”.

“Overtone Crystal”: A crystal calibrated to the desired frequency at a major response other than the fundamental. An Overtone crystal can be calibrated as “Series” or “Parallel”.

“Equivalent Series Resistance (E.S.R)”: The resistance of the crystal at Series resonance is simply the motional resistance R1. In the region of parallel resonance, its value increases to:

$$E.S.R = R1 \left[1 + \frac{C_0}{C_L} \right]^2$$

Therefore, E.S.R is the resistance or loss of the crystal in the parallel resonance region.

Note, it is important to understand that every crystal is able to operate in fundamental or any overtone mode, at series and parallel resonance. It is just a matter of matching the crystal manufacturer’s calibration condition to the condition applied to the crystal terminals by the surrounding circuitry.